

### M-SR 5.6/120

$f' = 118.9 \text{ mm}$      $\beta_p' = 1.001$   
 $s_F = -96.3 \text{ mm}$      $s_{EP} = 22.6 \text{ mm}$   
 $s_{F'} = 93.7 \text{ mm}$      $s_{A'P} = -25.3 \text{ mm}$   
 $HH' = 0.6 \text{ mm}$      $\Sigma d = 48.5 \text{ mm}$

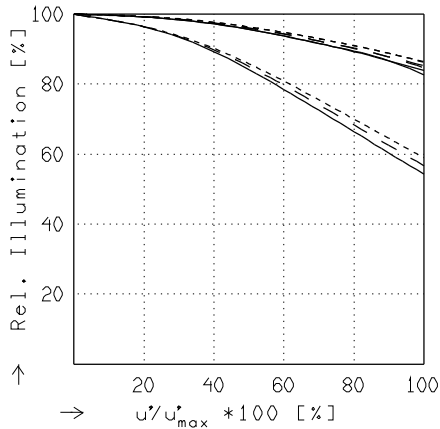
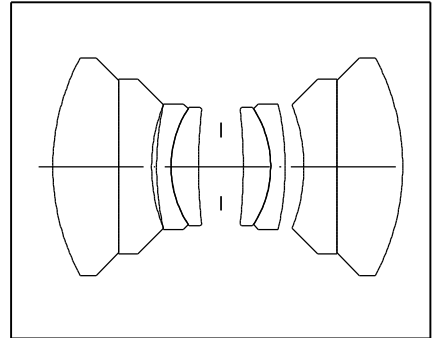

### RELATIVE ILLUMINATION

The relative illumination is shown for the given focal distances or magnifications.

	$f / 5.6$	$f / 8.0$	$f / 11.0$
—	$\beta' = -0.2600$	$u'_{\max} = 45.1$	$00' = 727.$
- -	$\beta' = -0.3200$	$u'_{\max} = 45.1$	$00' = 648.$
----	$\beta' = -0.3800$	$u'_{\max} = 45.1$	$00' = 597.$

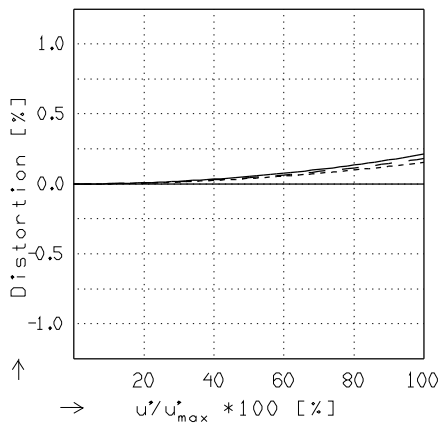

### DISTORTION

Distortion is shown for the given focal distances or magnifications. Positive values indicate pincushion distortion and negative values barrel distortion.

—	$\beta' = -0.2600$	$u'_{\max} = 45.1$	$00' = 727.$
- -	$\beta' = -0.3200$	$u'_{\max} = 45.1$	$00' = 648.$
----	$\beta' = -0.3800$	$u'_{\max} = 45.1$	$00' = 597.$

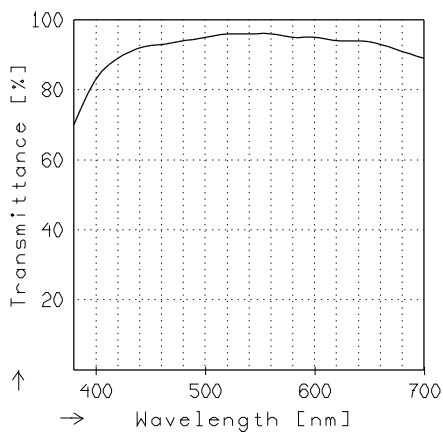

### TRANSMITTANCE

Relative spectral transmittance is shown with reference to wavelength.

M-SR 5.6/120 BETA -0.375..-0.625

$f' = 119.8 \text{ mm}$      $\beta'_p = 0.986$   
 $s_F = -95.4 \text{ mm}$      $s_{EP} = 26.1 \text{ mm}$   
 $s_{F'} = 93.9 \text{ mm}$      $s_{A'P} = -24.2 \text{ mm}$   
 $HH' = -0.5 \text{ mm}$      $\Sigma d = 49.7 \text{ mm}$

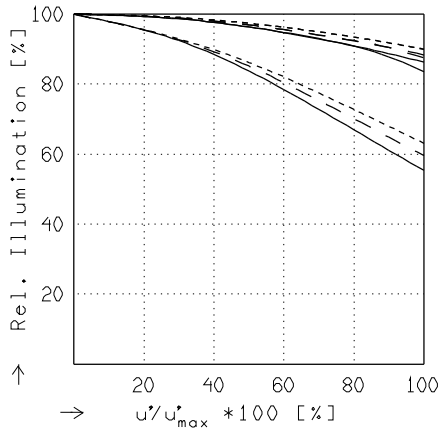
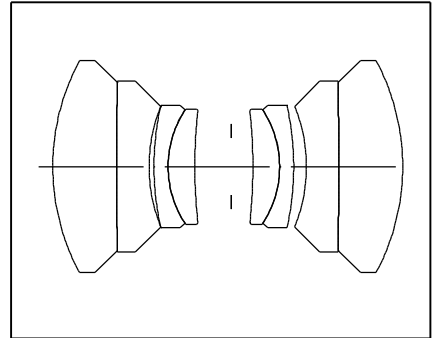

RELATIVE ILLUMINATION

The relative illumination is shown for the given focal distances or magnifications.

	$f / 5.6$	$f / 8.0$	$f / 11.0$
—	$\beta' = -0.3750$	$u'_{\max} = 45.1$	$00' = 603.$
- -	$\beta' = -0.5000$	$u'_{\max} = 45.0$	$00' = 538.$
- · - ·	$\beta' = -0.6250$	$u'_{\max} = 45.0$	$00' = 505.$

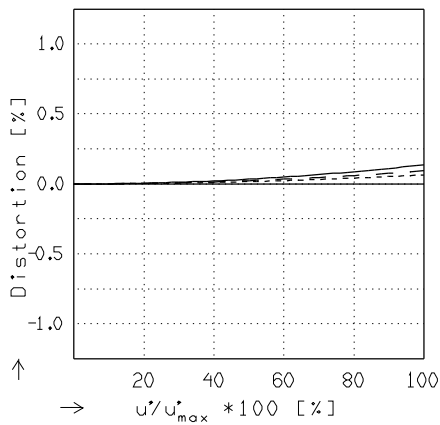

DISTORTION

Distortion is shown for the given focal distances or magnifications. Positive values indicate pincushion distortion and negative values barrel distortion.

—	$\beta' = -0.3750$	$u'_{\max} = 45.0$	$00' = 603.$
- -	$\beta' = -0.5000$	$u'_{\max} = 45.0$	$00' = 538.$
- · - ·	$\beta' = -0.6250$	$u'_{\max} = 45.0$	$00' = 505.$

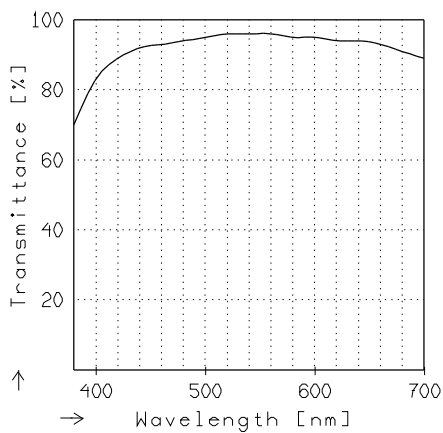

TRANSMITTANCE

Relative spectral transmittance is shown with reference to wavelength.

M-SR 5.6/120 BETA -0.625..-0.875

$f' = 120,2 \text{ mm}$        $\beta'_p = 0,994$   
 $s_F = -94,8 \text{ mm}$        $s_{EP} = 26,1 \text{ mm}$   
 $s_{F'} = 94,1 \text{ mm}$        $s_{A'P} = -25,4 \text{ mm}$   
 $HH' = -1,2 \text{ mm}$        $\Sigma d = 50,4 \text{ mm}$

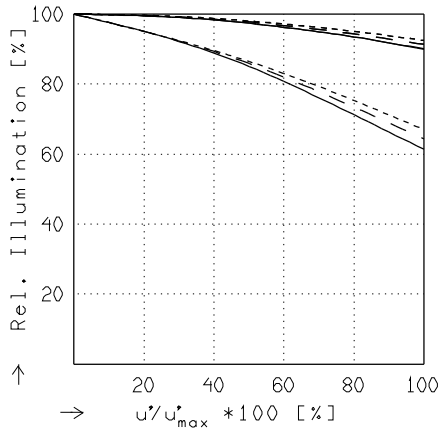
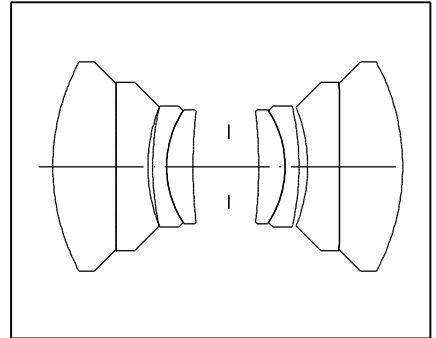

RELATIVE ILLUMINATION

The relative illumination is shown for the given focal distances or magnifications.

	f / 5.6	f / 8.0	f / 11.0
—	$\beta' = -0.6250$	$u'_{max} = 45.0$	$00' = 507.$
- -	$\beta' = -0.7500$	$u'_{max} = 45.0$	$00' = 490.$
- · - ·	$\beta' = -0.8750$	$u'_{max} = 45.0$	$00' = 482.$

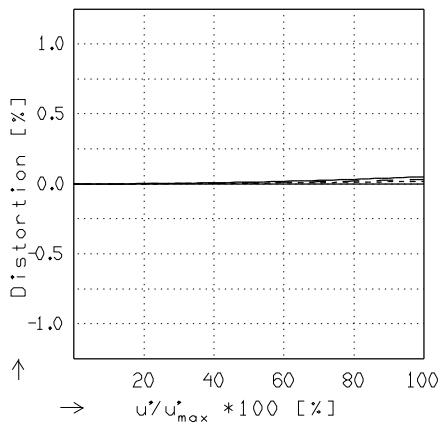

DISTORTION

Distortion is shown for the given focal distances or magnifications. Positive values indicate pincushion distortion and negative values barrel distortion.

—	$\beta' = -0.6250$	$u'_{max} = 45.0$	$00' = 507.$
- -	$\beta' = -0.7500$	$u'_{max} = 45.0$	$00' = 490.$
- · - ·	$\beta' = -0.8750$	$u'_{max} = 45.0$	$00' = 482.$

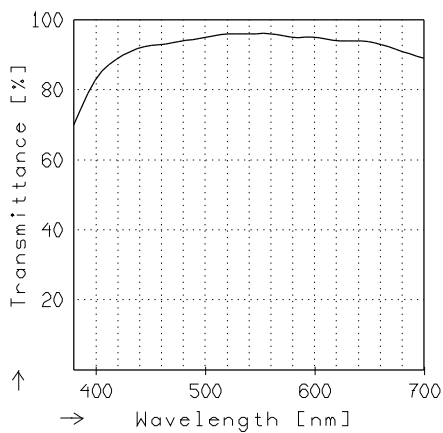

TRANSMITTANCE

Relative spectral transmittance is shown with reference to wavelength.

M-SR 5.6/120 BETA -0.875..-1.125

$f' = 120.7 \text{ mm}$      $\beta'_p = 1.002$   
 $s_F = -94.3 \text{ mm}$      $s_{EP} = 26.1 \text{ mm}$   
 $s_{F'} = 94.3 \text{ mm}$      $s_{A'P} = -26.6 \text{ mm}$   
 $HH' = -1.8 \text{ mm}$      $\Sigma d = 50.9 \text{ mm}$

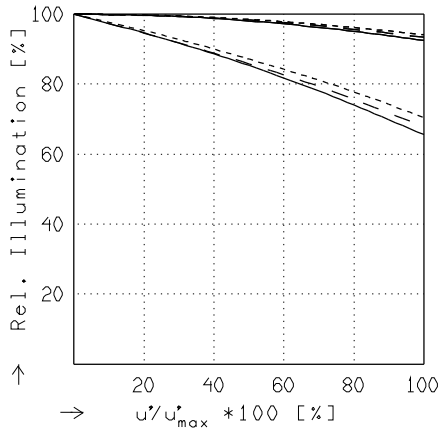
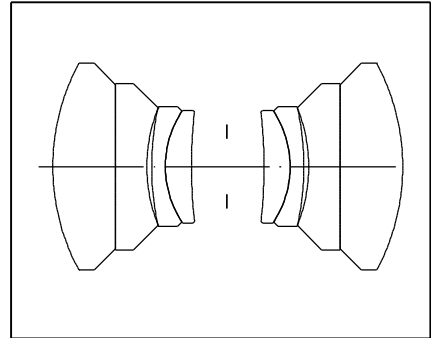

RELATIVE ILLUMINATION

The relative illumination is shown for the given focal distances or magnifications.

	$f / 5.6$	$f / 8.0$	$f / 11.0$
—	$\beta' = -0.8750$	$u'_{\max} = 45.0$	$00' = 483.$
- -	$\beta' = -1.0000$	$u'_{\max} = 45.0$	$00' = 481.$
.....	$\beta' = -1.1250$	$u'_{\max} = 45.0$	$00' = 483.$

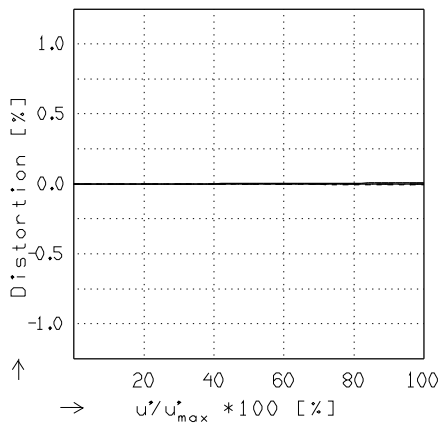

DISTORTION

Distortion is shown for the given focal distances or magnifications. Positive values indicate pincushion distortion and negative values barrel distortion.

—	$\beta' = -0.8750$	$u'_{\max} = 45.0$	$00' = 483.$
- -	$\beta' = -1.0000$	$u'_{\max} = 45.0$	$00' = 481.$
.....	$\beta' = -1.1250$	$u'_{\max} = 45.0$	$00' = 483.$

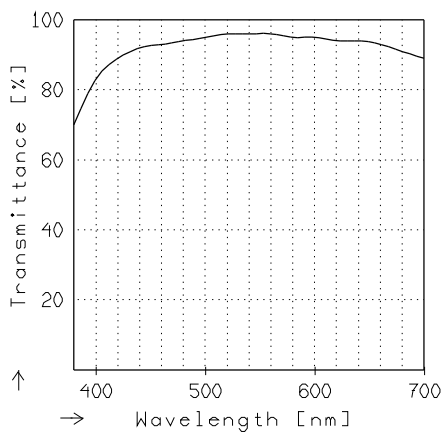

TRANSMITTANCE

Relative spectral transmittance is shown with reference to wavelength.